

- 1) Image shown without shingles and veneer siding (by builder)
- 2) These plans are intended as a guide ONLY! Feel free to make changes, adjustments and revisions to suit your requirements.
- 3) We do not assume to know the size and type of fowl being harbored in this coop. Adjustments may be necessary on a project-per-project basis.
- 4) This coop is large enough for approximately 10-20 chickens, Geese, turkey and other fowl will require revisions.
- 5) Always use safety equipment and safe construction practices! We will not be held liable for any personal injuries that may occur.

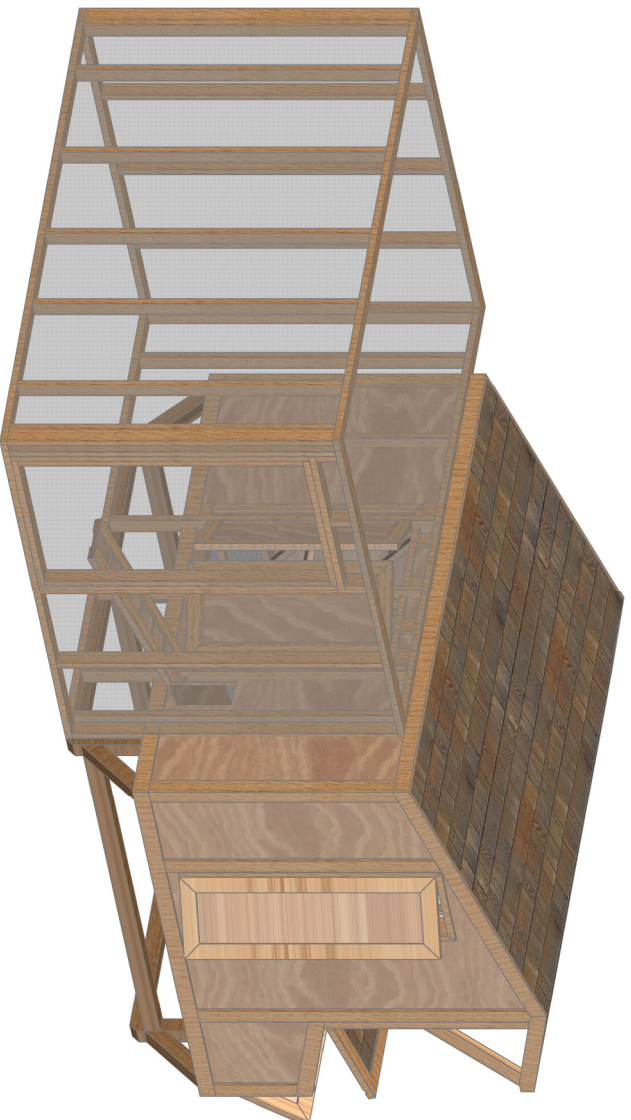
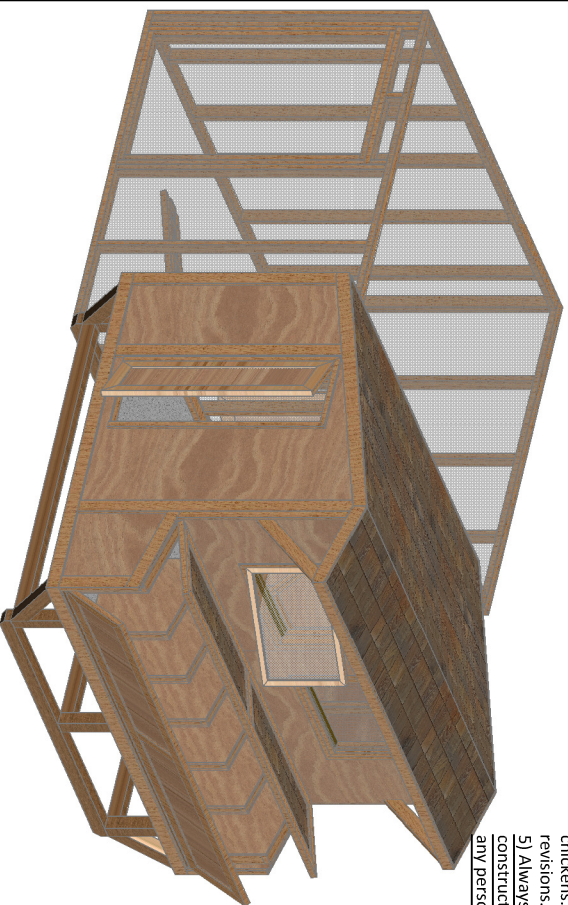

## Material List

Description	mm	Dimensions english	Quantity
<b>Base</b>			
Sled	90x90x3000	4x4x10'	7
Long Plank	45x90x2400	2x4x10'	2
Short Plank	45x90x2400	2x4x8'	7
Plywood Sheet	1200x2400x19	4x8'x $\frac{3}{4}$ "	4
Fiberglass Board	By Builder	By Builder	
<b>Side Walls</b>			
Planks	45x90x2400	2x4x8'	24
Plywood Sheathing	1200x2400x19	4x8'x $\frac{3}{4}$ "	6
<b>Rear Wall</b>			
Rear Support Plank	45x90x2400	2x4x8'	9
Rear Ridge Plank	45x90x3000	2x4x10'	1
Rear Sheathing	1200x2400x19	4x8'x $\frac{3}{4}$ "	2
2x6 Rear Sill	45x150x3000	2x6x10'	1
<b>Nesting Boxes</b>			
Nesting Box Support	45x90x3000	2x4x10'	10
Nesting Box Base	1200x2400x19	4x8'x $\frac{3}{4}$ "	2
Plywood Sheet	1200x2400x19	4x8'x $\frac{3}{4}$ "	4
<b>Front Wall &amp; Doors</b>			
Door Planks	45x90x2400	2x4x8'	6
Front Wall and Door Sheath.	1200x2400x19	4x8'x $\frac{3}{4}$ "	10
Front Wall Support Plank	45x90x3000	2x4x10'	4
<b>Roost</b>			
Roost Supports	45x90x2400	2x4x8'	2
Roost Planks	45x90x2400	2x4x8'	3
<b>Roof</b>			
Roof Planks	45x90x2400	2x4x8'	16
Sheathing	1200x2400x19	4x8'x $\frac{3}{4}$ "	6
<b>Trim</b>			
long 1x4 planks	25x90x3000	1x4x10'	4
short 1x4 planks	25x90x2400	1x4x8'	12
<b>Miscellaneous: To be determined by builder</b>			
Handles	By Builder	By Builder	4
Hinges	By Builder	By Builder	12
Veneer/Siding	By Builder	By Builder	300 cu. ft.
Wood Sealant	By Builder	By Builder	2 Gallons
Paint	By Builder	By Builder	2 Gallons
Screws	#20-30x60mm	By Builder	300 Min.
Shingles	By Builder	By Builder	1 Box Min.
Latches	By Builder	By Builder	4 Min.

1) If this coop will not be moved, we recommend setting it on a concrete base to prevent water intrusion. Begin by laying out the EXTERIOR perimeter of the concrete base. Feel free to use the completed base platform as a guide. You can use stakes and string (see below).

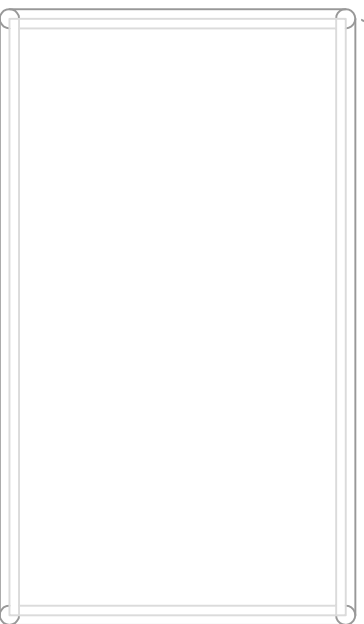

2) Dig a trench at least 8" (200mm) wide by 6" (150mm) deep around the entire perimeter of the platform. You need to at least be able to align the outside edge of the platform with the trench below. The platform is going to "sit" on this concrete form.

3) Construct a wooden brace around both the exterior AND interior edges of the trench (as shown). Now would be a good time to get some threaded rebar at least  $\frac{3}{8}$ "  $\varnothing$  (14mm) at least 1'-6" (450mm) in length. Pour concrete into the trench between the wooden braces. Follow manufacturer instructions on mixing and pouring the concrete. Tamp the rebar **THREADS UP** at regular intervals down the center of the trench.

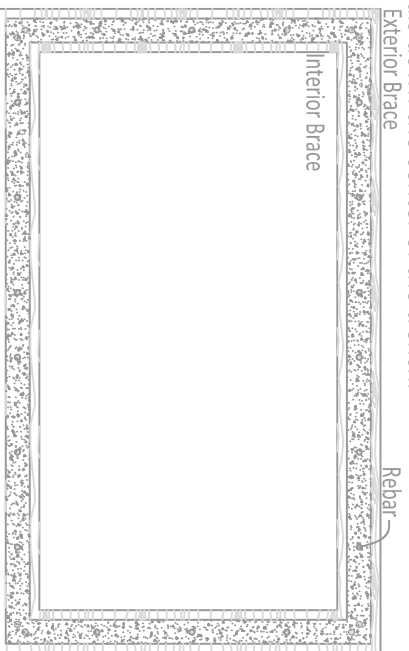

**Make sure to use a level ensure the rebar runs straight vertically!** It is OK if you aren't exactly equidistant just as long as each rebar piece runs close to the center of the platform's edge. Fill the concrete to the top edges of the braces and use water to smooth over the top.

4) This method may be a little unorthodox, but it sure is easy. After the concrete sets and the rebar is thoroughly set, lay the platform on top of the rebar, being square, it should sit easy enough. **MAKE SURE THE PLATFORM IS SQUARE!**

5) Once the platform is square on the rebar, give it a good "WHACK!" with a hammer or soft mallet, just enough to make a good indent on the wood where the rebar is located. Be sure to hit the board wherever it touches rebar or you will miss a piece!

6) Flip the platform structure over and you will see exactly where to drill through the structure to attach it to the rebar. Make sure your drill bit is just as big as the indent for a snug fit.

7) Lay a layer of sealant foam along the inside and outside edge of the platform structure and let dry.

8) Flip the structure back over and carefully align the holes with the rebar. You may need to smack the structure down to get a good, solid connection with the concrete below.

9) Using washers, anchor the structure to the concrete. Use a grinder to remove any excess rebar sticking up over the nut. If desired, use a torch to weld the nut and rebar together.

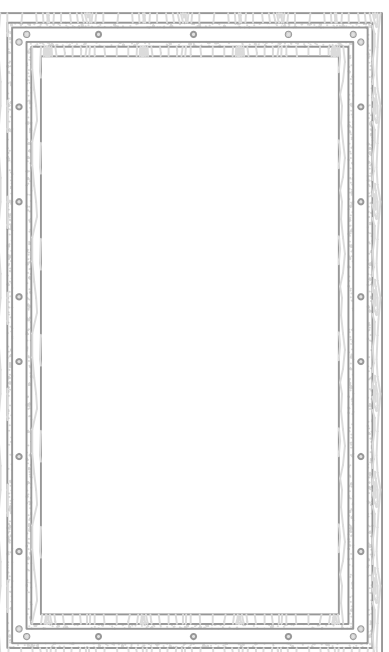

You can feel free to try and remove the wooden braces if you would like. It may take some hitting with a hammer or even a crowbar.

Before we get started, it is important that the builder choose pressure treated lumber for the base of this coop. This coop is going to be designed to be relocated. The sleds on the bottom are to be constructed of pressure treated lumber to prevent water intrusion and rot. If a concrete base is going to be used, pressure treated timber is still recommended but not vital.

1) To begin, start by cutting two (2) 4x4's 10'-0" (90x90x3000mm). You will need to cut a total of ten (10) 4x4 (90x90mm) horizontal supports at 7'-5" (2225mm). This should give you an even 10' (3000mm) length by 8' (2400mm) width base for the coop.

2) At this point, attachments are very important. You MAY choose to use screws or a pneumatic nailer (nail gun). Being this is the base and this coop will be heavy, If you are going to move it, we recommend using at least  $\frac{3}{8}$ "x5" (13x125mm) lag screws to hold the sled components together. You will want to countersink the heads so they are not in the way of the final trim later on.

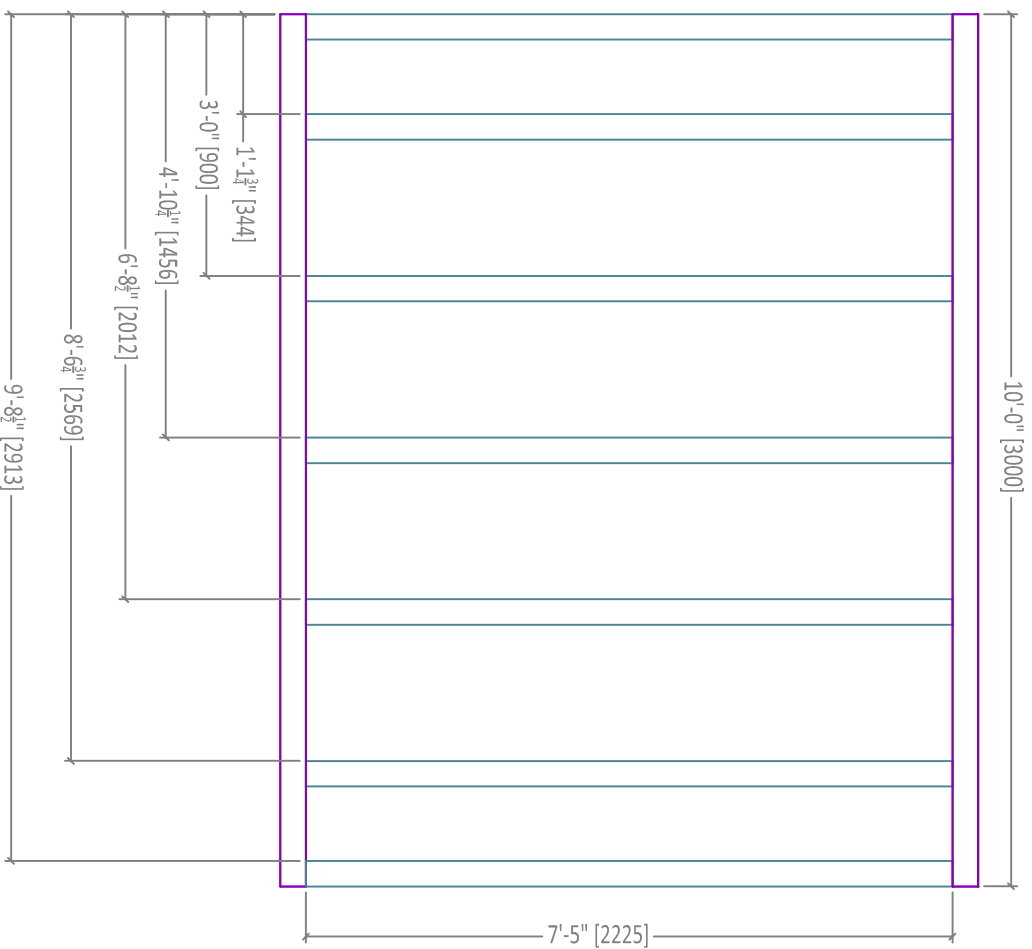

For those who wish to move the coop, the base will be constructed as detailed below. It is easiest to determine which side will be the top and which side will be the bottom. Tip the platform bottom-up and construct from the bottom of the platform up.

1) With your main platform constructed, you will need to cut the pieces detailed below. **All pieces are 4x4 (90x90mm) lumber.**

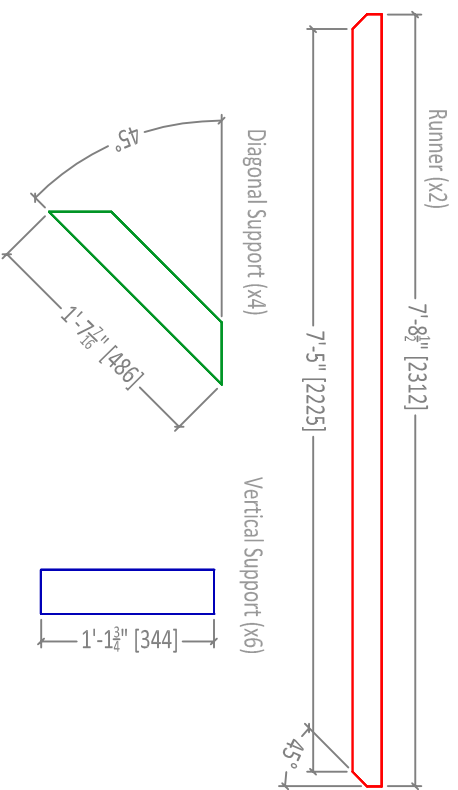

2) Attach the horizontal supports to the very exterior edges of the platform structure as shown below. Be sure they align with the LONG side of the structure.

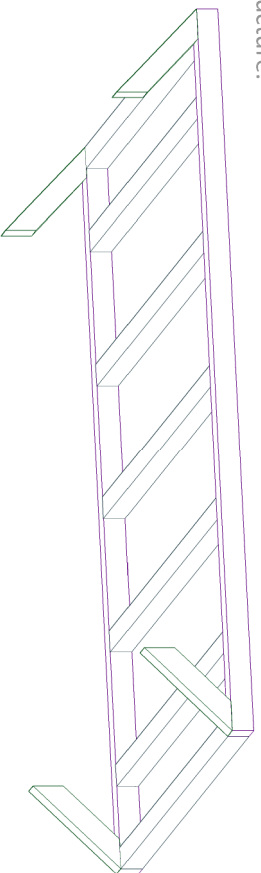

3) Attach the vertical supports to the end of the diagonal supports and through the top of the platform structure down into the vertical supports. Attach two vertical supports to the center of the long platform side as shown below.

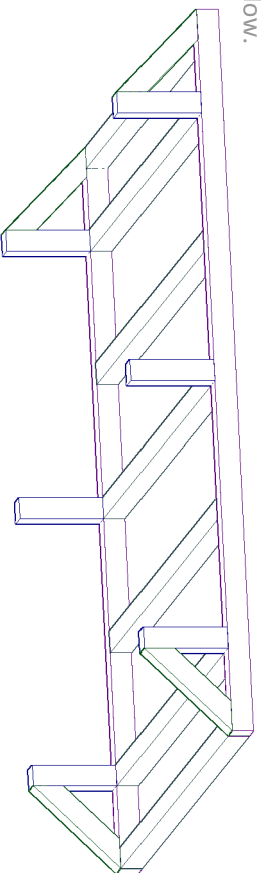

4) Attach the sleds with lag screws. The sleds will hold the brunt of the force while the coop is in motion, you will want to use very heavy duty connectors if not lag screws.

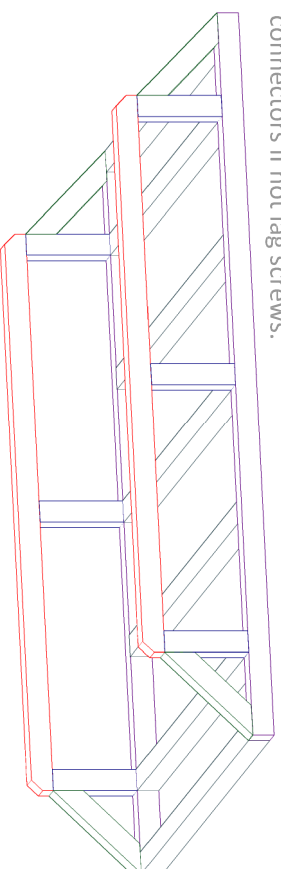

5) Remember those extra three short horizontal supports left over from the construction of the platform? Attach those between the bottoms of the vertical supports for stability.

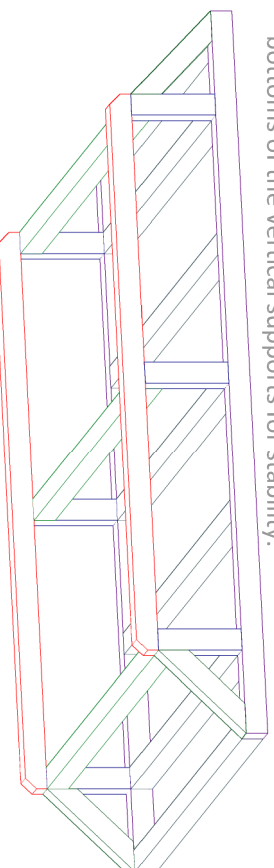

6) After you tip the structure back onto its top, this is what you should have up to this point.



- 1) Once the platform structure is complete, use a circular or table saw to cut four (4) sheets of plywood into 4x5' (1200x1500mm) sheets. Set the 3x4' (1200x900mm) sheets aside for later.
- 2) Square up one corner of the platform with one of the sheets of plywood.
- 3) Repeat for remaining three sheets. The sheets should align in the center of the platform on the center support as shown below.

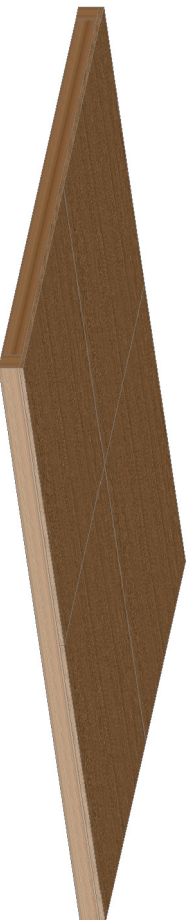

- 3) This step is recommended but not required. Attach a glass board veneer over the top of the sheeting. Follow manufacturer instructions carefully and be sure to drill into supports beneath plywood flooring.

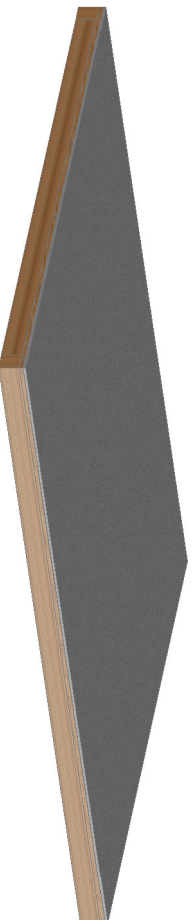

- 4) Begin construction on the entrance wall as shown below. Be sure to cut carefully and wear safety equipment. All mitered edges are 15°.

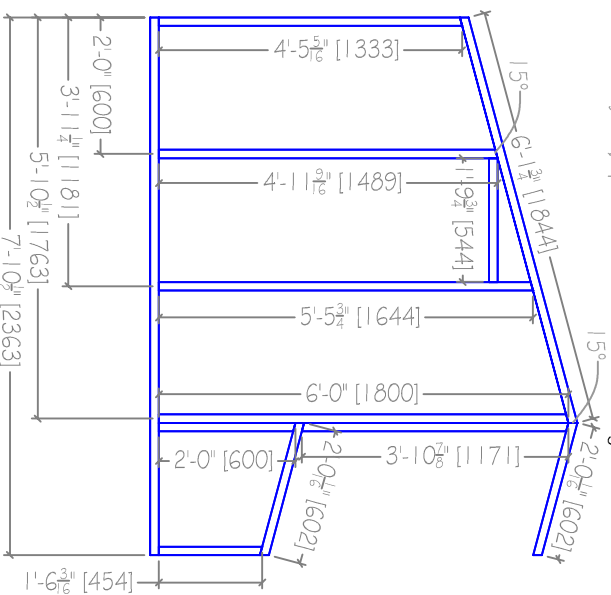

- 5) Now for the side wall. It is very much the same as the entrance wall but without a door header.

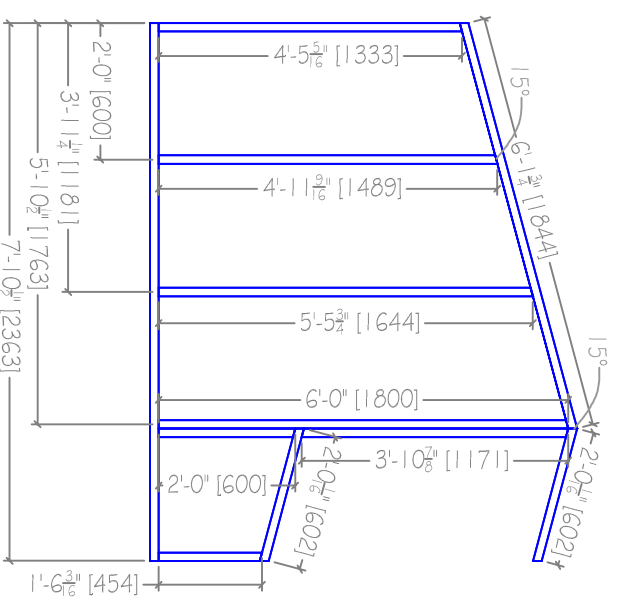

- 6) If you have noticed the wall is 1/2" (35mm) short, this is because the nesting box front wall will be set on the front of the platform and we will need the space for the wall.
- 7) Align each of the walls with the rear of the platform and attach with screws. We recommend against a nail gun because screws will give you a tighter hold AND nail guns may crack the glass board (if used).



8) For the rear wall, measure and cut planks as shown below. The sill is a 2x6 (45x150mm). You will need to use a circular or table saw to rip the end flush with the rear of the side wall supports.

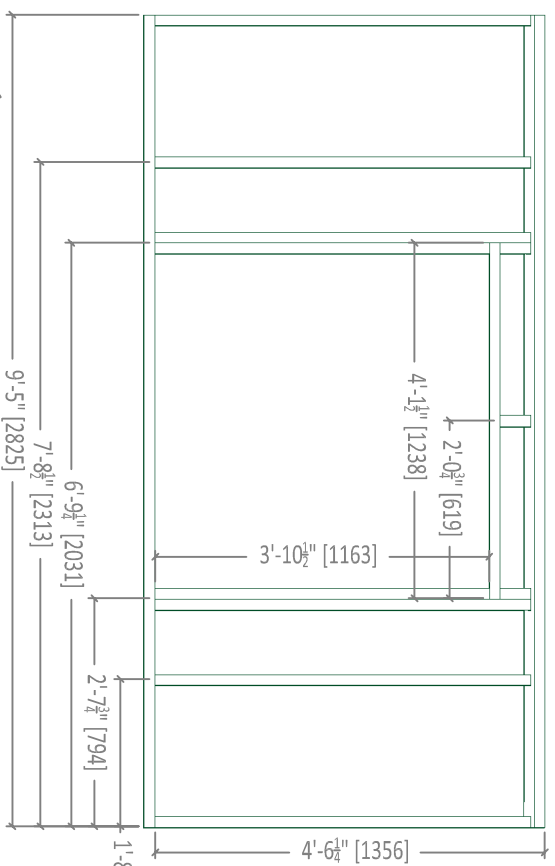

Make sure the top of the 2x6 (45x150mm) sill sits flush with the bottom of the sill plates on the side walls. You will add more rafters and need to attach them to the rear wall sill. This will ensure the sheathing is flat and even.

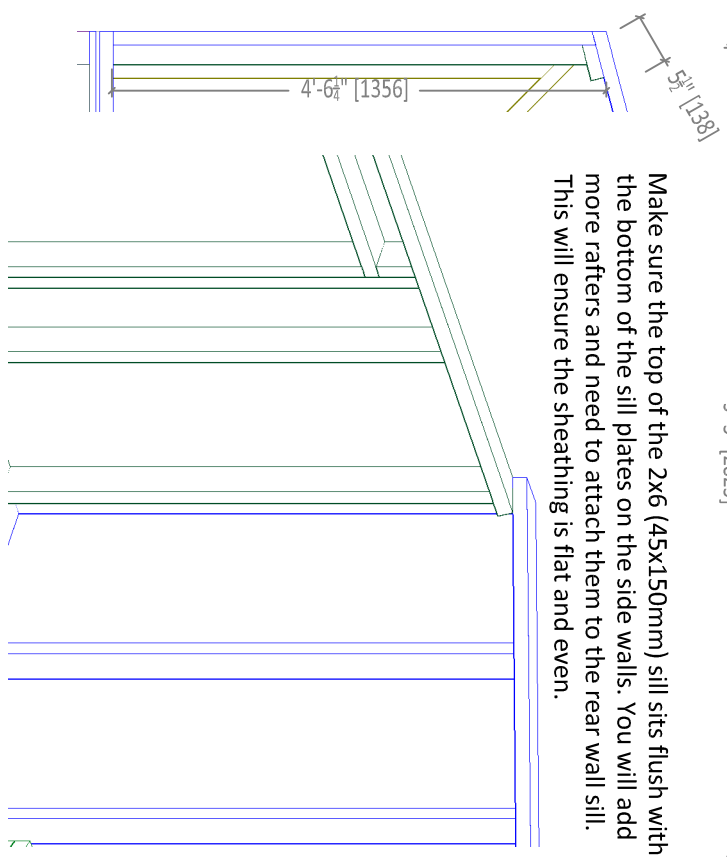

9) Now would be a good time to build and attach the roost structure. Start by ripping five (5) 10' (3000mm) 2x4 (45x90mm) planks down the center lengthwise. Assemble as shown below. Attach one side to the side wall and attach the other support structure flush with the inside edge of the user access frame.

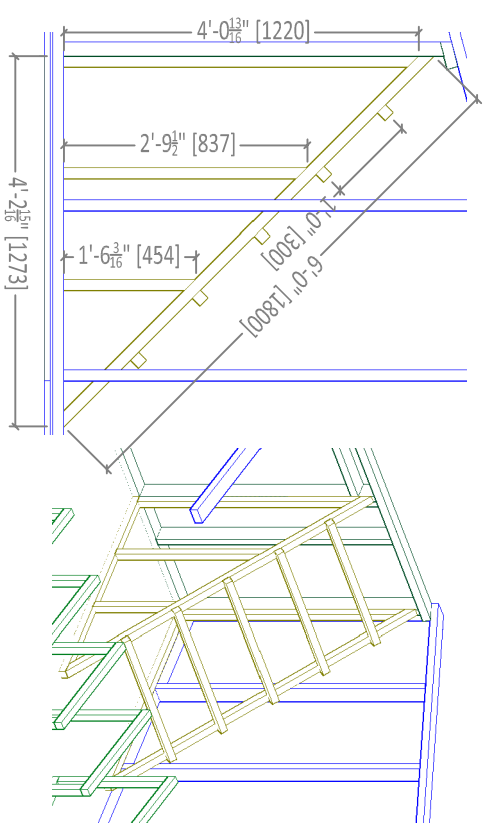

10) For the nesting box, rip a 8' (2400mm) 2x4 (45x90mm) down the middle lengthwise. Assemble as shown below. Repeat this process for as many nesting boxes as needed. Space these at the minimum 12" apart. Spacing will be determined by the average size of fowl to be housed.

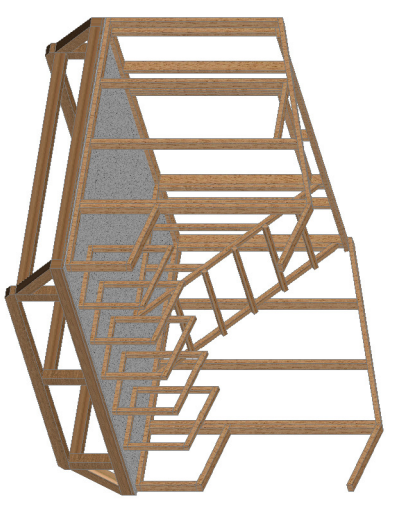
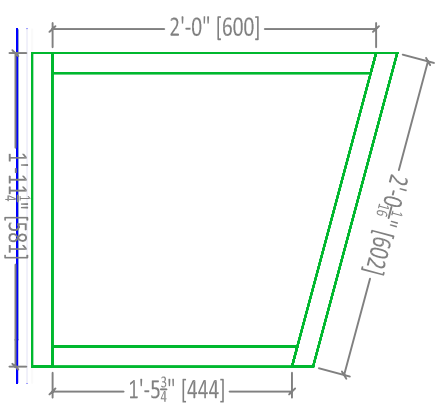

11) For the nesting box front panel you will need to start by determining what size and type of plywood sheathing you are going to use to sheath the exterior and enclose the structure. We recommend  $\frac{1}{2}$ " (13mm) oak plywood as it is strong and weather resistant.

12) Router down the center length of two (2) 10' (3000mm) planks on end (we recommend a guard) and a 6' (1800mm) plank on end (as shown below). Make sure the router matches the width of the plywood to be used. If the bit is too large, the plywood will shift around in the gouge. If the bit is too small the plywood won't fit.

13) Miter the ends and make sure they come together as shown below.

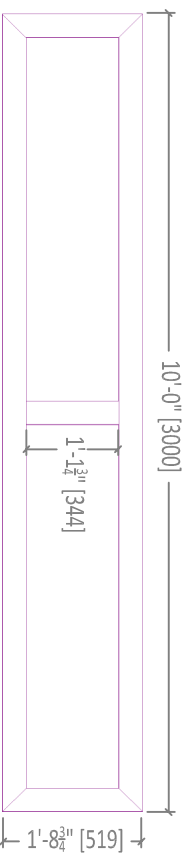

14) You should have a small piece of the 6' (1800mm) piece left with a gouge in one side. Measure and cut the ends square as detailed above. Router down the center of the opposite end so you have a piece with two gouges.



15) Cut a sheet of plywood into two (2) sections as shown below.

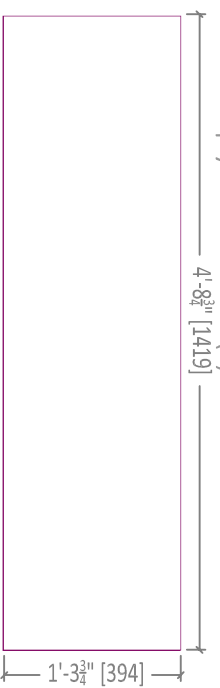

16) Without glue or attachments, assemble as shown below. Do NOT attach until you are certain the pieces will come together snugly.

17) If the pieces fit together and everything looks good, go ahead and run a bead of glue down each gouge and assemble all of the pieces to form the front panel shown below. We recommend allowing the glue time to dry before attaching with screws as a nail gun can break the oak plywood. Also, drill pilot holes for the screws, you will only have one shot at getting the screw in the right place. Hold the drill straight up or sideways and drill straight into the plywood sheet from the outside.

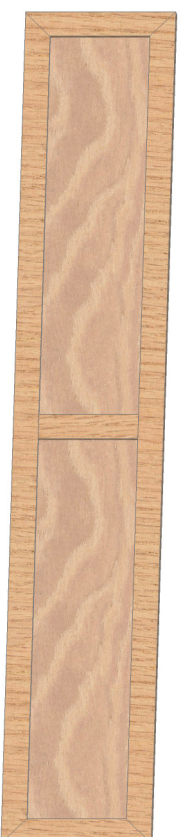

So far, the structure should start coming together as shown below. If you want to open the front panel DO NOT attach it to the structure. We are going to make it so the user can clean the nesting boxes easily. If you do not want the front panel to open, go ahead and attach it to the structure.



18) You will need to rip four (4) 10' (3000mm) planks as shown below. These are going to form the crown. Use a circular or table saw and make sure you have the correct pitch of 15°.

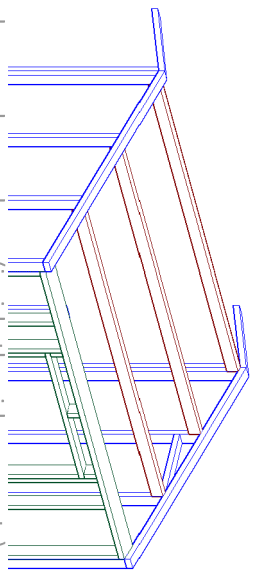
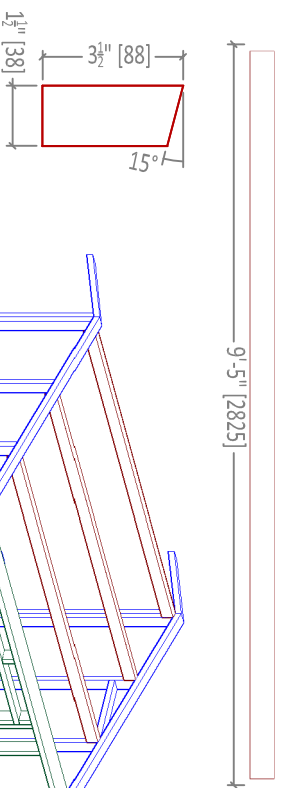

19) Place the rafters in place as shown above (inside the side supports). You can use 5" screws, but, if you want a really strong structure, use a metal plate and bolt the rafters through the rafters and through the side supports. You may even use two plates and bolt completely through.

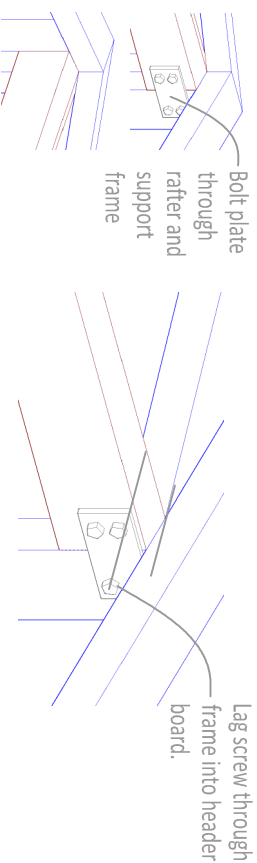

Be careful around the door header. If you wish to screw it together, that is fine. If you want to still bolt, line up the top bolt hole with the header and use a lag screw through the door frame INTO the header. Attach the frame as regular. You will want to use round head bolts and face the bolts OUTWARD away from the entrance. Do NOT use a plate on the inside, it will interfere with the door swing. Use washers to take the load on the rafter. Also, be careful around the front crown. If you do decide to use bolts and plates, like the door frame, use lag screws through the frame and crown. You will need a smooth face for a front wall plank.

You will need this face smooth so use a lag screw from the back

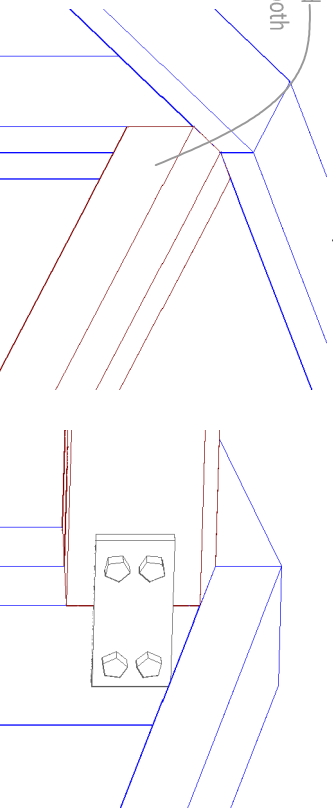

20) Cut purlins EXACTLY as those cut for the side and entrance wall sill plates. Center them at 2' (600mm) across the top of the rafters as shown below.

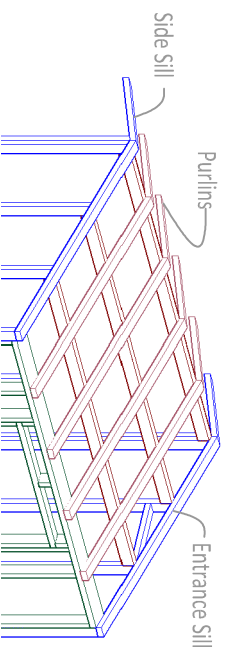

21) Now, we need to complete the front wall. Now would be a good time to think about windows for the coop. If you do not wish to purchase windows, we have included diagrams to make your own rough windows and vents. Begin by ripping two boards as detailed below.

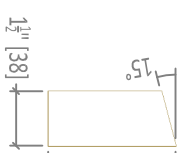

22) Attach them at the top and bottom of the front wall face as shown below

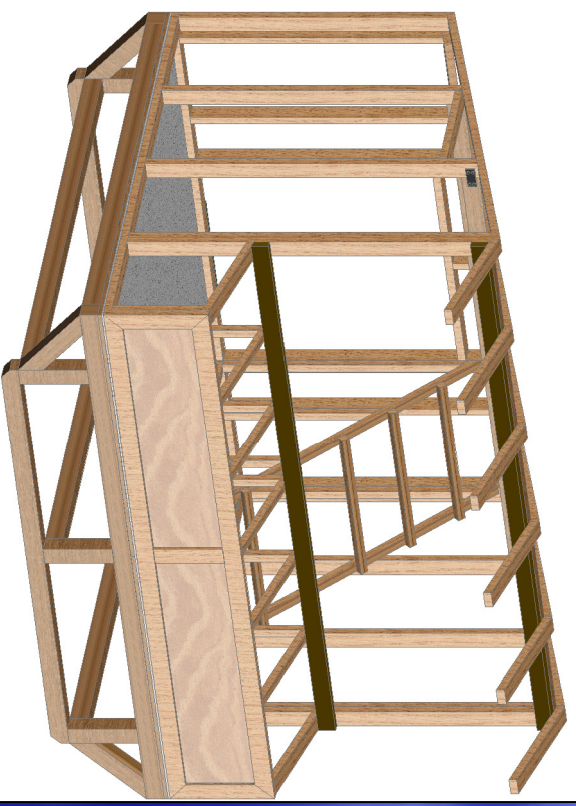

22) Now to begin with the sheathing. We started with the side and entrance because they are very similar. **NOTE:** When you layout the entrance, make sure your saw blade cuts **INSIDE** the line for the door area, the width of the saw blade will add up all around the perimeter and allow you to close the door. **KEEP** this sheet as your door panel. Label and mark so you don't accidentally cut it.

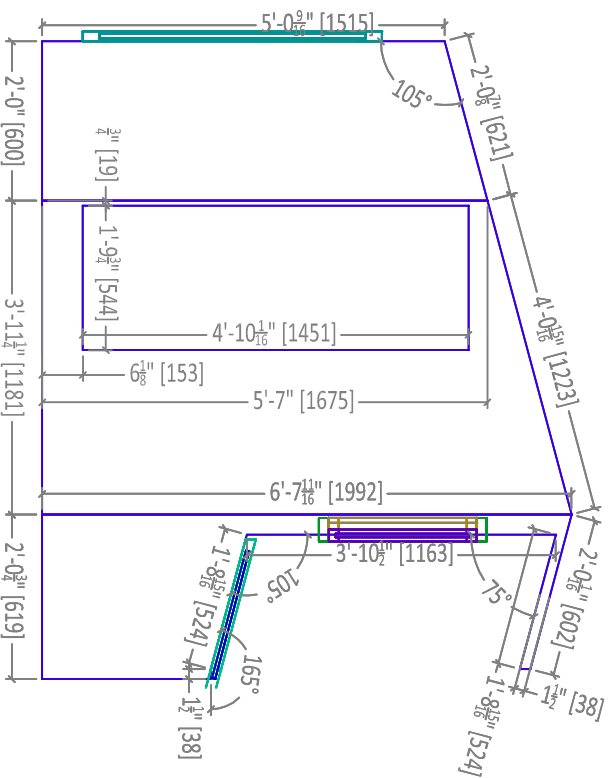

LAYOUT EACH SHEET CAREFULLY, it's an awful lot of waste if you do not. **VERIFY EVERY DIMENSION!** Make sure edges are square and flush.

23) The side sheathing is MUCH the same as the entrance, only no door. **IF YOUR NESTING BOX OPENS, DO NOT ATTACH TO THE NESTING BOX PANEL, ATTACH THE SHEETING TO THE NESTING BOX FRAME!**

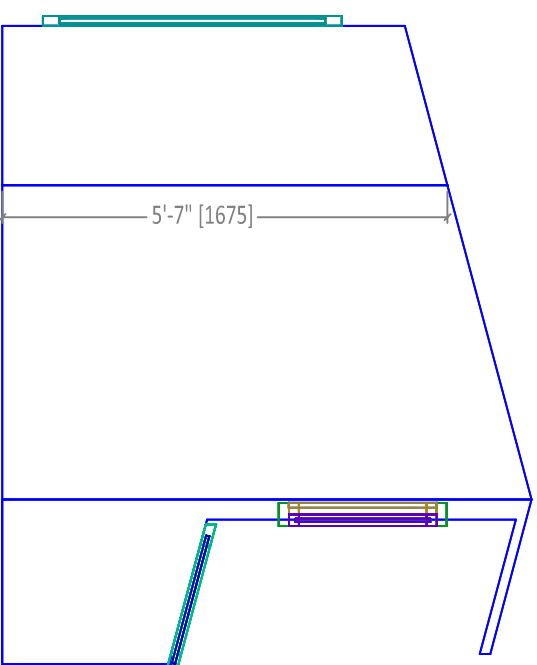

24) The rear sheeting is pretty simple compared to the side and entrance sheeting. You may want to use scraps from the side and entrance sheeting. **MAKE SURE YOU DON'T USE THE ENTRANCE DOOR PANEL!** Notice the top of the sheeting needs to be angled to flush with the pitch of the roof, this will make sheeting the roof MUCH easier, don't forget this step!

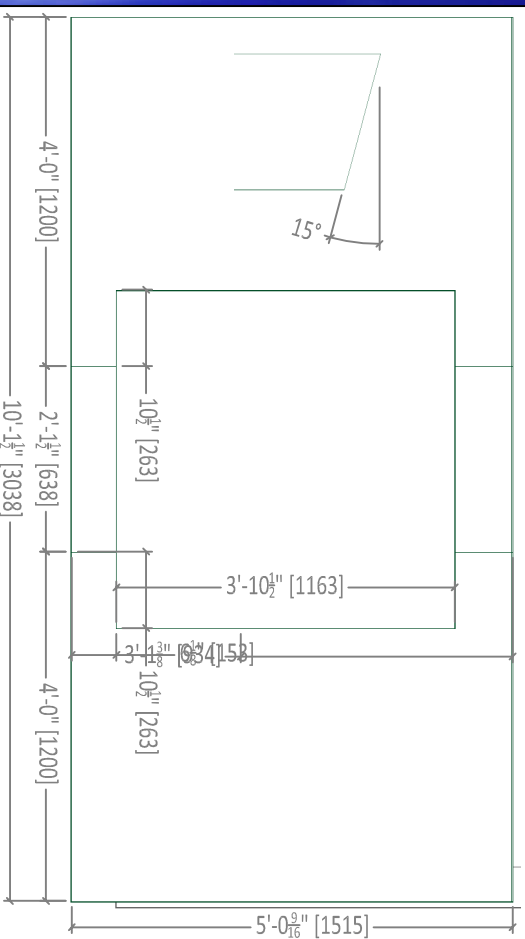

27) Center the window frame in the wall frame as shown.

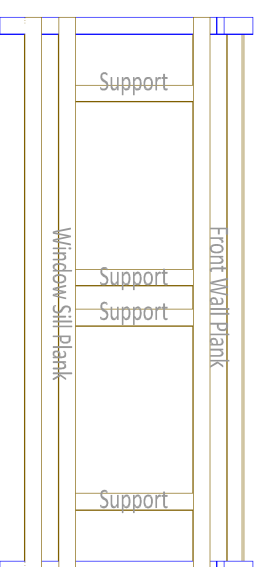

28) Attach the vent through the rear of the front wall. YOU may have to use a soft mallet or dead-blow hammer to "tap" the screen into place. It should be a snug fit. Attach with nails or screws up through the front of the frame. Make sure the screen frame is flush with the rear face of the window frame.

29) Use hinges to attach the window. Which side is up the the builder. If you attach the hinges to the top, you will need some type of support system to keep the windows open. We recommend attaching the hinges on the side and using a slide pin or hook and eye-pin to latch.

30) Attach weather stripping around the interior window sill so there is a weather-tight seal when you close the windows.

LAYOUT EACH SHEET CAREFULLY, it's an awful lot of waste if you do not. **VERIFY EVERY DIMENSION!** Make sure edges are square and flush.

25) Now, to install the windows, you will first have to add a sill plank so the window will fit. Have an assistant hold a window frame in place and mark where the sill plank will be located. Make sure the sill is level and tack down with screws.

26) After you have the sill plank in place, cut and attach the window supports as shown below.

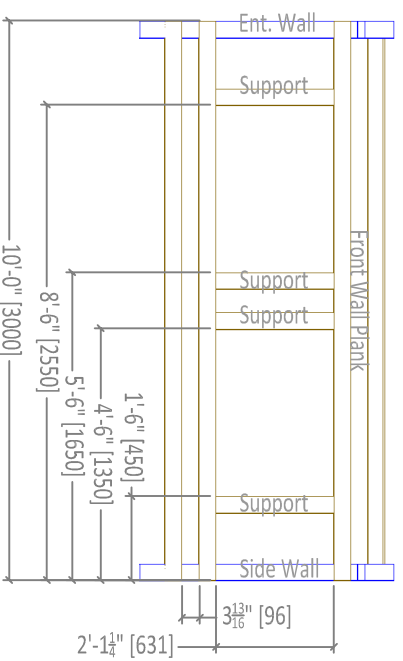

31) You will need to MEASURE all openings and make sure the dimensions are accurate. Layout and Cut two (2) sheets of plywood as shown below.

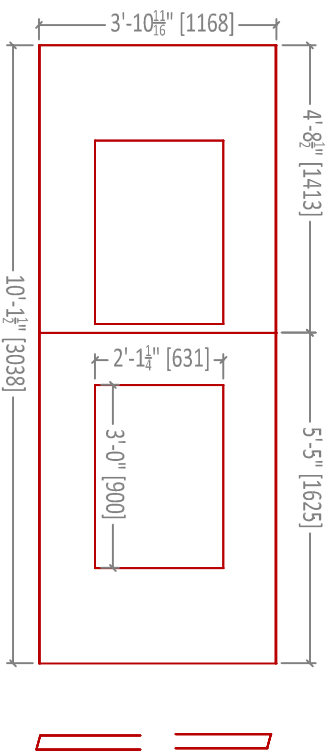

Don't forget to measure and cut the miter on the plywood sheets so they fit snug into the space provided. You should be able to "tip" the sheets into place around the window frames.



32) You should probably cut some nesting box dividers and attach them to the nesting box frames before we get too far.

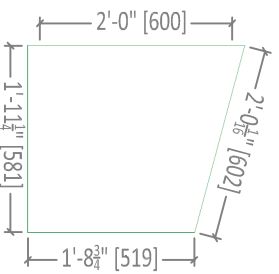

33) Now let's work on the frames for the doors. These are simple compared to some you have already done. Simply miter 2x6 (45x150mm) planks as shown below.

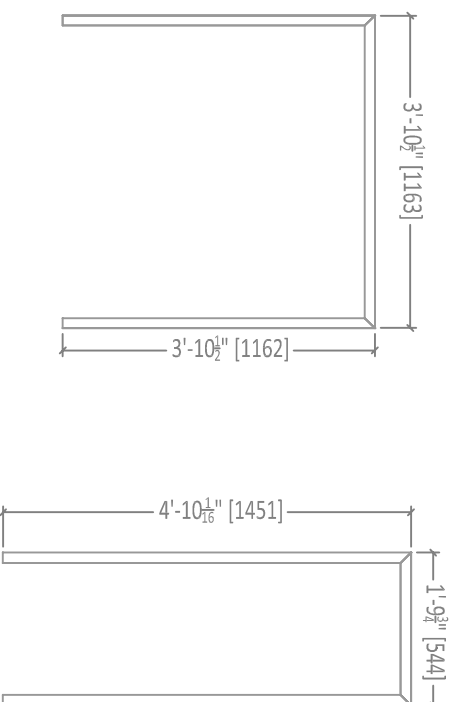

34) Attach the door frames with  $\frac{3}{4}$ " (25mm) overhang. You will end up trimming the outside and the overhang will stick out the width of a 1x4 (25x90mm) plank. Use a piece of 1x4 (25x90mm) to get the correct overhang as shown below.

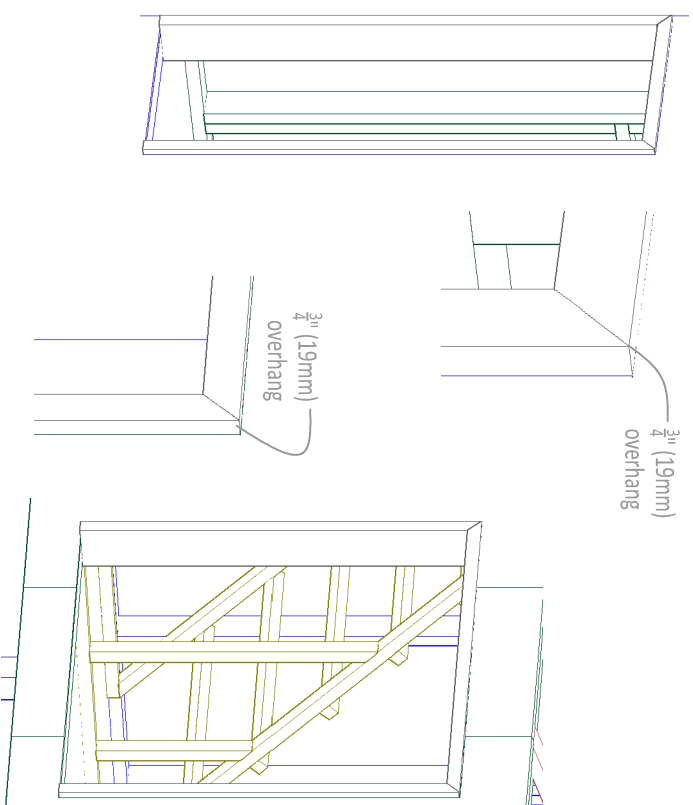

35) First thing you are going to want to do upon completion of the nesting box lid is miter on edge so it sits flush with the wall when closed (see below).

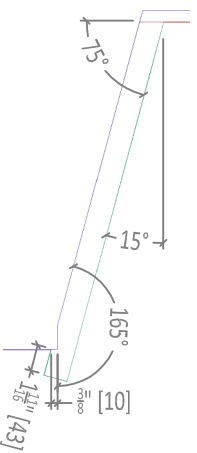

NOTE: If you want to cut the seat BEFORE assembling the lid, this is perfectly fine. We choose this order so the user can set the assembled lid on the nesting box frame and mark the cuts they will need to make.

- 1) Clamp the plank at a 15° angle.
  - 2) Attach your router guide or adjust the table saw.
  - 3) Rip or router the planks as shown above. You will need to rip the entire length of the long plank AND the short ends of each of the cross braces.
- If you wish use a  $\frac{3}{4}$ " (19mm) thick piece of weather tape to cushion the lid. The weather tape should absorb any of the lip and keep the nesting box weather tight.

36) Attach hinges to the exterior of each of the rear doors and hang in place on the rear door frame. Use a slide bolt on top and bottom to keep the doors locked in place. If you wish, you may also install the slide pins vertically on the inside top and bottom. Use a drill to drill a hole for the slide pin to anchor the door closed.

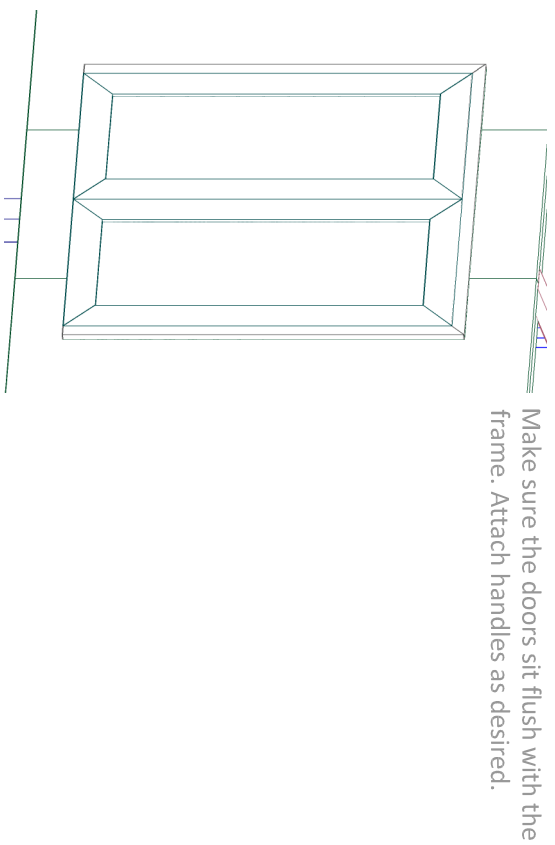

If you are going to let your chickens run out of the coop run, you may put a slide bolt in the center so you can just open the doors to let them out and slide the pin to close them in.

37) One more time, use a router with a guide or a table saw to rip a groove down the center edge of a 14' (4200mm) plank. Cut the entrance door frame and panel as shown below. Assemble in the same manner as rear doors.

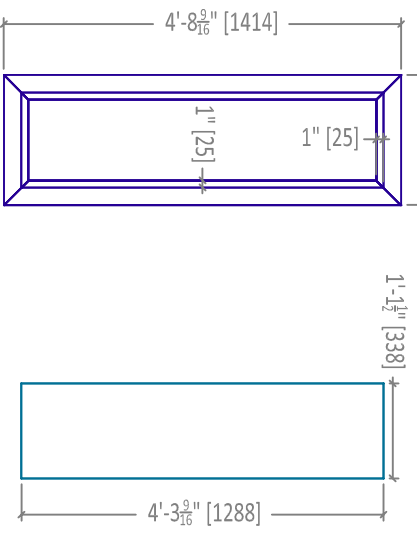

38) Attach hinges to the door frame and hang in the entrance frame. We have allowed  $\frac{1}{4}$ " swing to allow the door to swing freely. Apply a strip of weather tape to all sides of the door frame to ensure a weather-tight seat.



Hinge and handle style are up to the builder. We recommend either a slide pin or a hook and eye-pin as a latch to keep the door closed.

39) You are nearing completion on your new coop. It is time to sheath the roof. Start by cutting four (4) sheets of plywood as detailed below. Keep both sides.

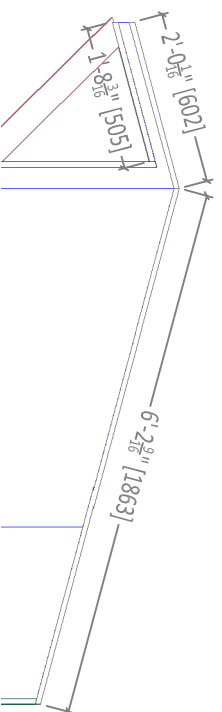

You can really sheath how you wish, but for a little guide we have numbered the detail below to show where sheathing can go to reduce the amount of waste.

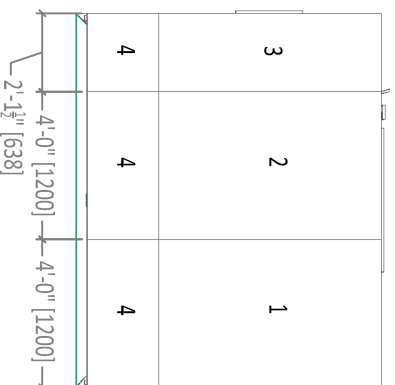
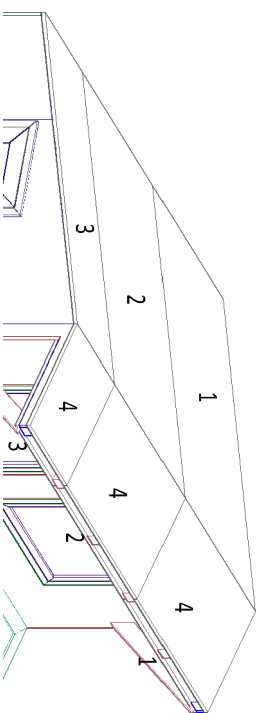

Now, all you need is a 1x4 (25x90mm) plank to put across the top, front of the overhang. Also, the roof should be strong enough to support most snow loads, but if you live in a high elevation area, add some braces to the overhang on the front. These are detailed in the following pages.

**IF YOU ARE INTENDING ON ADDING TRIM, DO NOT ATTACH ANYTHING TO THE FRONT OF THE OVERHANG! TRIM WILL BE DETAILED IN THE FOLLOWING PAGES!**

40) Now, for all intensive purposes you are done with the coop! Congratulations! We have included a list of trim pieces that will enhance the look and overall aesthetics of the coop. Those are continued on the next page but NOT REQUIRED.

**Some general notes:**

- 1) These drawings are intended as a guide ONLY. While the drawings are complete and may be followed carefully, you should ALWAYS check measurements to confirm. Saw blades vary in thickness with age, lumber thickness can vary by country or standard. Too many variables exist, not to mention the construction competency of the builder.
- 2) While these plans are written with the most basic steps laid out, some builder competency is expected. Especially with the trim as the pieces need to be tailored very specifically to fit just right. You also need to know how to use your own tools and to know what types of tools are listed in these drawings.
- 3) The chicken access, for all purposes is the rear door. We will be installing a smaller access in the rear of the coop, but this is up to the builder and is NOT REQUIRED.
- 4) Ramps and chicken runs are simple structures but drawings are included in the following pages.

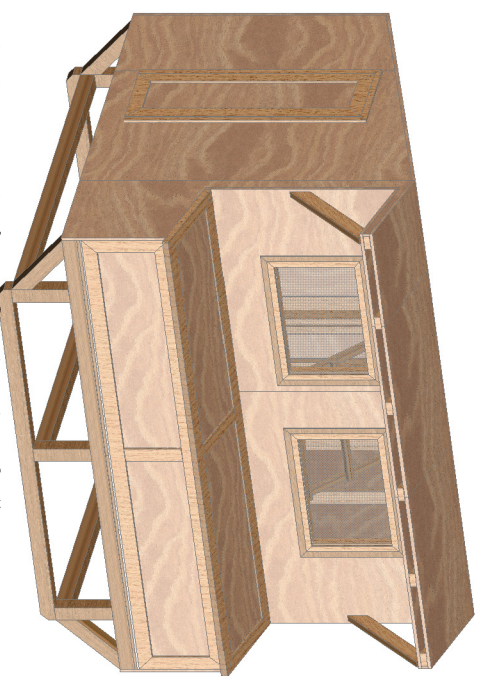

Dont forget the brace in the front. Simply hold a 3-4' (900-1200mm) plank against the side and mark your cuts.

For the windows, we are going to build a custom window size. **WARNING:** Always use protective equipment when cutting or breaking glass. Use caution with all glass panels to prevent breakage. Lay glass panels in safe, dry place until ready to use.

1) Cut a 10' 2x4 (45x90x3000mm) plank as shown below. All corners are mitered at 45°. You will need two (2) of these sill frames.

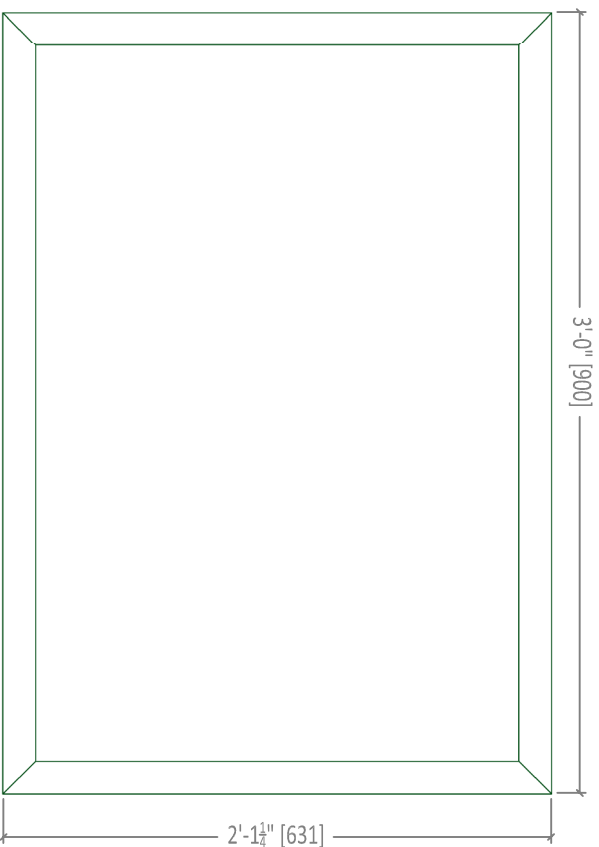

Go ahead and glue all of the corners and screw or nail together. Just make sure the frames are square and all edges are flush!

2) Rip a 10' 2x4 (45x90x3000mm) down the center using a table saw or circular saw with a guard. You will end up with two (2) 10' (3000mm) planks that are about 1 1/2"x1 3/4" (37mmx44mm)

3) Cut each piece as shown below. The pieces should just fit inside the frame built earlier!   
 2'-9 1/8" [825]

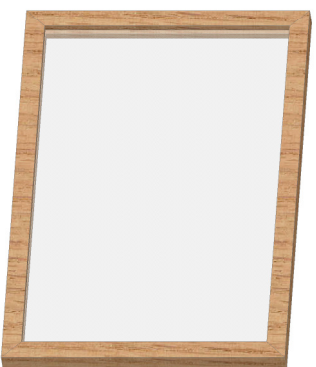
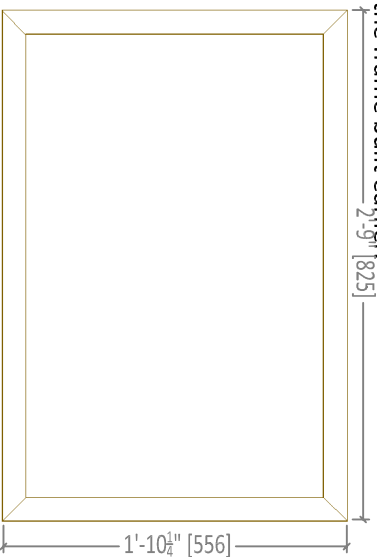

4) Cut a sheet of screen large enough to overlap the edges of the frame roughly by half.

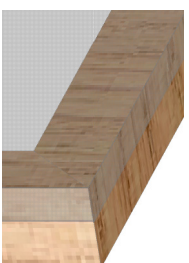

5) Make two (2) of these vent frames.

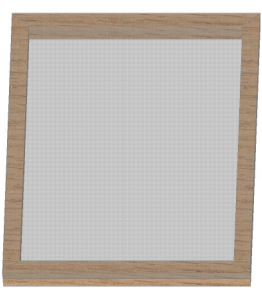

6) Rip another 10' plank in half just like for the vent frames. You will need a router with a guide or a table saw with the applicable attachments.

7) Router a 1/2" (13mm) gouge down the center of each piece. Be sure you router the entire piece BEFORE cutting to length as shown. This will ensure a continuous gouge the entire length of the window frame.

8) Place the glass sheet (you don't need to use glass (feel free to substitute any clear material such as PVC or plastic)) into the frame and check to make sure the frame fits around the pane snugly.

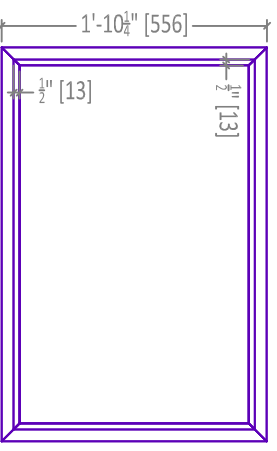
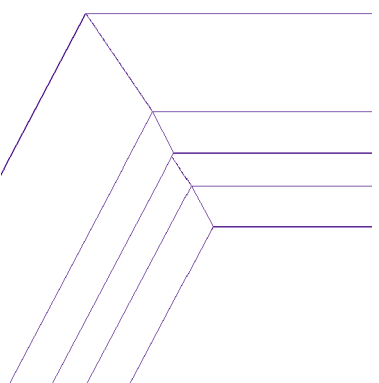

We have allowed 1/4" (6-7mm) of clearance. Make sure the window swings freely. Before Gluing or assembling the window check to make sure the swing is unimpeded. **DO NOT ATTACH THE VENT OR THE WINDOW TO THE FRAME YET, YOU STILL NEED TO ATTACH THE FRAME TO THE FRONT WALL**

9) Run a bead of silicone sealant (or equivalent) down the length of each gouge and glue the ends together around the pane.

10) Allow to set before attaching with screws or nails. We recommend screws, as pneumatic nails can break the seal. ALWAYS use extreme caution to ensure the screws or nails go straight into the frame. Make sure you do NOT impact the pane material as such may cause cracking or breakage.

11) You will also need two of these windows. We recommend working on one at a time to ensure the correct frame pieces do not get mixed up.

This page is intended for those who wish to trim out the coop. Trim may be applied for many reasons, but the most popular reason is simply to make the coop look aesthetically pleasing. The trim's primary purpose in these drawings is to cover any plywood seams or wood edges.

In these plans we made all of the overhang and roof rafters plumb cut. This means the overhang and the rafter's end is straight vertically. If you want to make trimming a little easier feel free to leave the ends square. It will require a little additional fore-planning and some adjustments to these plans, but it is your coop.

We will provide the overall dimensions of the trim pieces. All pieces are 1x4 (25x90mm). How the trim gets cut is up to you. Measure CAREFULLY, trim can be a tricky item and there are construction professionals dedicated solely to its installation. **AS ALWAYS USE EXTREME CAUTION TO PREVENT WASTE AND INJURY!**

We will start with the easy stuff. The base trim is nothing you haven't done before. Simply measure and miter the ends..if your front panel on the nesting box opens, do NOT attach the front trim to the side trim (you will close the box permanently). Leave the corners "free floating" and attach the trim to the panel structure.

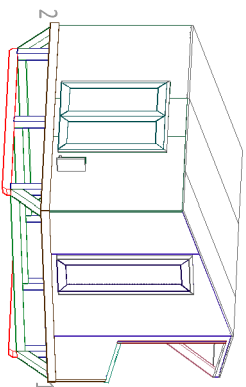
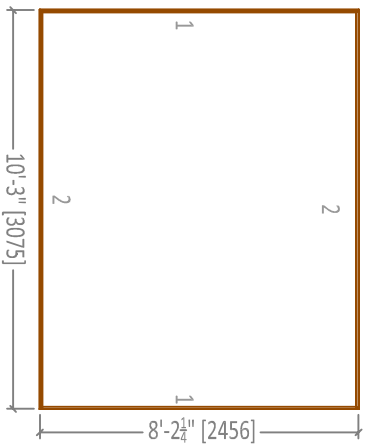

Working our way up, you will need two each of the pieces below. The mitered edge will be for the rear corner.

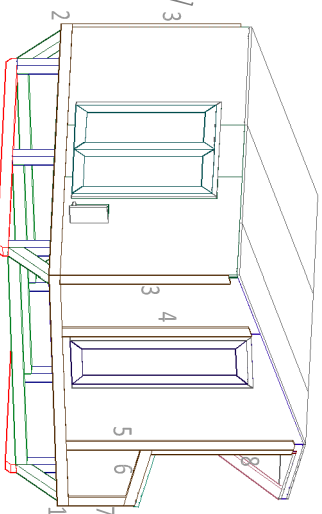
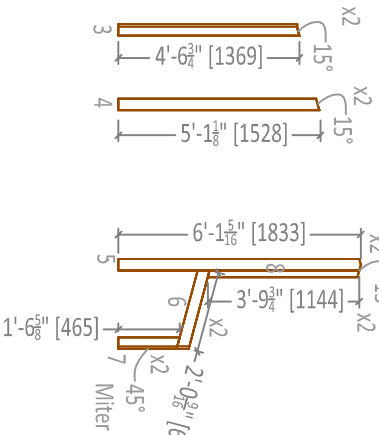

Around the back, cut as many pieces as detailed.

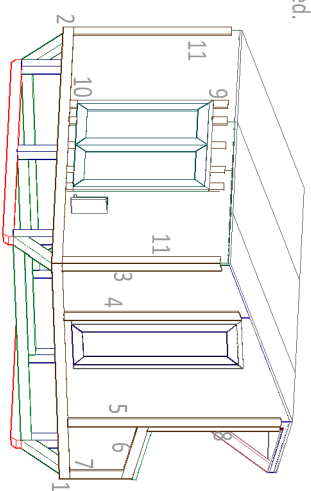
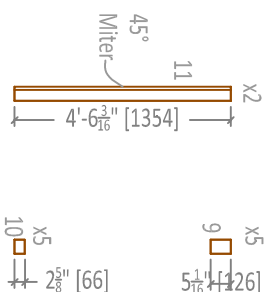

Now we need to work on the roof.

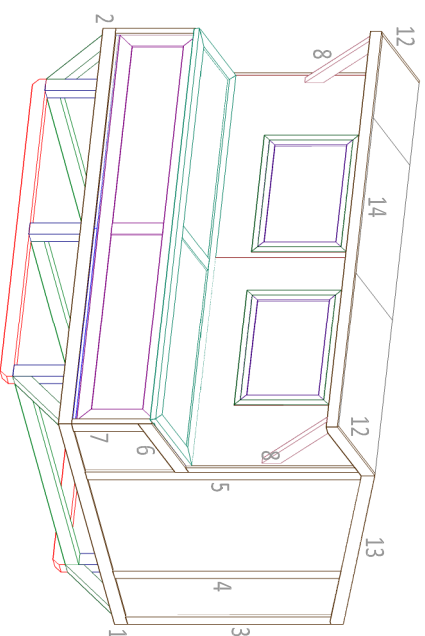
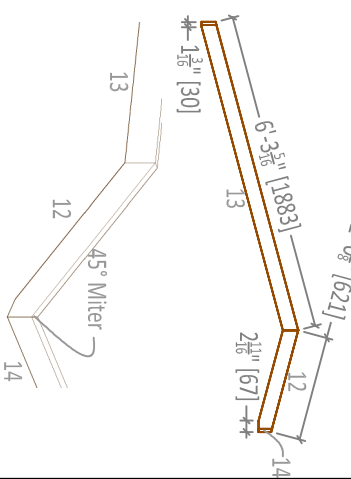
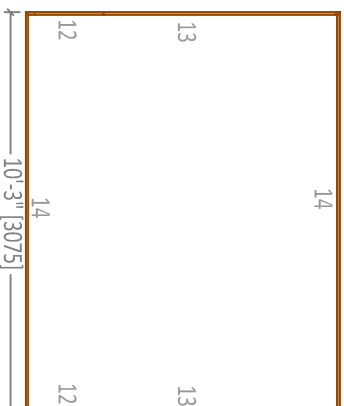

This page is intended as guidance for little projects that make the coop your own. This page will cover adding a chicken access and a ramp.

This coop was designed to use the larger access doors in the rear as a chicken access, but should you live in colder climates, you will want a smaller chicken access to keep the cold out of the coop and keep warmth in.

Also, on that note. If you do live where the weather can get really cold, we recommend at least insulating the interior walls. You will want to put some interior sheathing inside or else the chickens will use the insulation in their nests and the insulation is not good for the overall health of the chickens.

Ok, for the chicken access, pick a spot on the rear wall that you can cut out. Keep the scrap for a door. If you live in inclement weather, you will also want to frame in the access as shown. We have chosen the space between the door supports and the nearest stud. If you have larger fowl, the space to the left is also a good spot. Either way, you will have to frame in around the opening, **ESPECIALLY** if you live in a colder region (insulation will have to go around it).

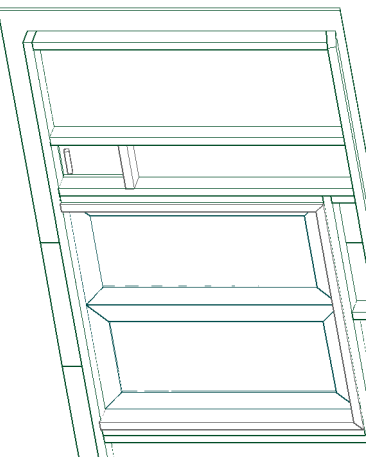

Use the scrap cut from the opening for a door that can be opened and closed. We recommend just putting hinges on one side and use a hook and eye-pin latch to keep it closed.

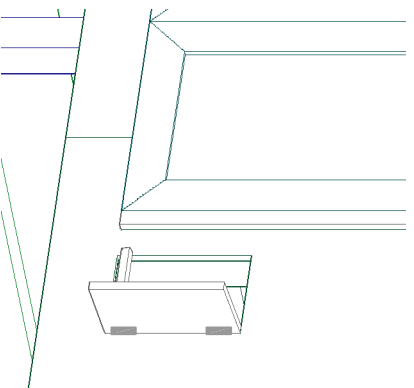

Now, whether you have a chicken access or not, you will need a ramp to let the chickens get into and out of the coop. You can simply slap a rough ramp together with scrap plywood at least 3 feet (900mm) long and 1 foot (300mm) wide, but this is such a nice coop, we are going to lead you through making a nicer ramp.

You will need a piece of scrap plywood roughly 3-4' (900-1200mm) by 6" (150mm), 2 scrap wood pieces 3-4 feet (900-1200mm) long and plenty of 6" (150mm) 1x4 (25x90mm) or 2x4 (45x90mm) pieces.

- 1) Rip a groove down the center of the planks (you have routered enough to almost be a professional). Make sure to rip through the thin edge.
- 2) Cut the plywood to a nice rectangle the length of your router planks.
- 3) Run a bead of glue in each groove and assemble the ramp as shown.
- 4) Cut the scrap pieces into squares that will fit in between the sides of the ramp.
- 5) Screw or nail the ramp and the pieces together and you are done!

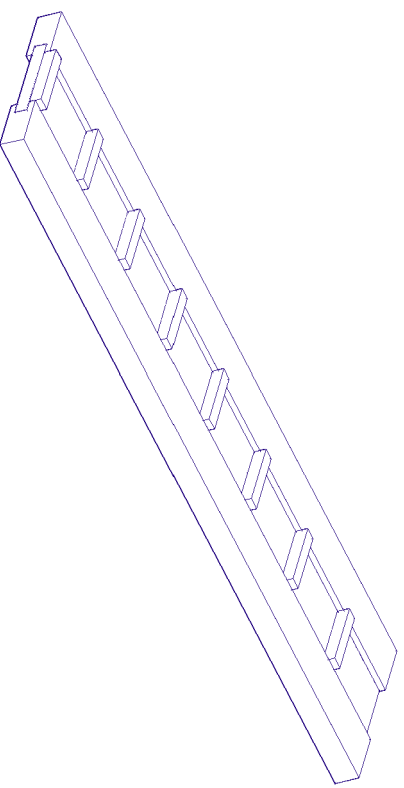

The chicken run is little more than a big box covered with chicken wire. We will provide the dimensions but after what you have done, we think you should be able to figure out how to construct the run. For those who cut the roof ends square, you will need to measure your maximum height!

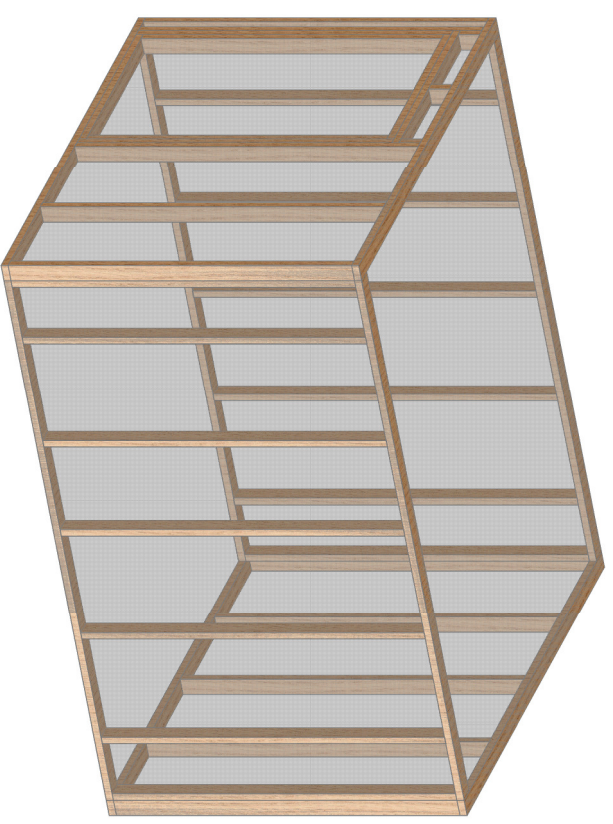
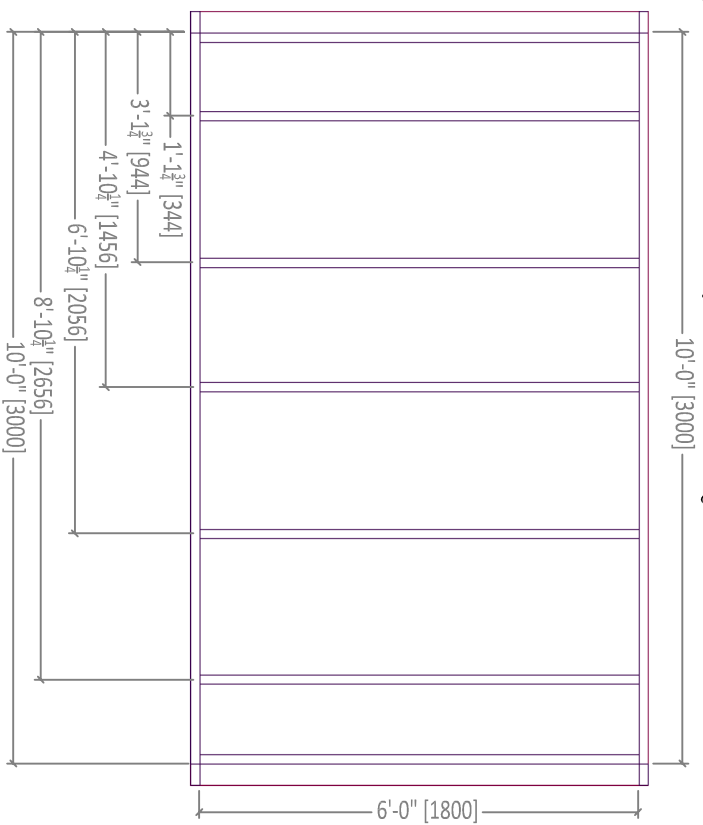

Once the run is completed, slide it over next to the coop, cut the chicken wire around the chicken access and the rear access, staple and you are done! Congratulations, your coop is ready to go!

